

N^o 1609



A.D. 1905

Date of Application, 26th Jan., 1905

Complete Specification Left, 21st July, 1905—Accepted, 4th Jan., 1906

PROVISIONAL SPECIFICATION.

“Improvements in or relating to the Treatment of Foodstuffs, more especially Cereals and their Products.”

We, JOSEPH APPLEBY, of 35, Pembroke Road, Bootle, and ARTHUR JOHN BANKS of 57, Lawton Road, Waterloo, near Liverpool, both in the County of Lancaster, Miller and Analytical Chemist respectively, do hereby declare the nature of this invention to be as follows:—

5 It has long been known that both living and dead organic matter, are more or less susceptible to the action of solar light as well as to varying portions of the visible and invisible rays of the solar spectrum. The influence of rays possessing great chemical activity in connection with the anabolic and metabolic changes of organised structure, has been rendered technically available by
10 quite recent researches on the phenomena of radio-activity.

Many varieties of food stuffs are capable of being improved in either their physical appearance or their physiological effect, by a modification of their molecular structure. Such alteration of chemical structure requires energy to be expended. Taking plant life as an instance, the amount of energy available
15 is really immense; but, unfortunately, the time required for the various steps in its transformation is also very considerable and from the manufacturers point of view altogether too excessive to admit of the natural time and order of the changes to be carried out. Hence, any means by which this period of time can be reduced, should be of commercial value.

20 Now our invention is designed to bring about an improvement in the condition of food stuffs, especially in respect to cereals and their products, such as flour, by inducing within the grain, or the products therefrom, chemical changes similar to those which occur in nature, or in the case of flour and cereal products by storage for several months. The invention consists
25 essentially in exposing the substance to be treated to the action of the emanation from radium or radio-active substances or to the action of the α (alpha) β (beta) or γ (gamma) rays derived from radium or the radio-active substances,

30 Treatment by exposure, under proper conditions to such rays, very materially reduces the time required to mature cereals and their products and food stuffs amenable to such action.

In the case of flour, semolina, and the like, a very great improvement is effected in respect to the purity of colour, the property of “strength” and their general keeping quality, whilst in all cases of such treatment, there is the
35 exceptionally marked advantage of an entire absence of the direct use or employment of chemical compounds in the ordinary sense of the term.

In our experiments we have brought the substance to be treated under the influence of a current of air aspirated from, or blown through a chamber, receptacle or vessel containing radium bromide. Other radio-active substances
40 may be employed, but with not such a good result, as their ionising action is less energetic.

We have mentioned the current of air aspirated from or blown through a

[Price 8d.]

Improvements in or relating to the Treatment of Foodstuffs.

chamber merely to illustrate what we have found to be a convenient way of applying the rays or emanations. It is obvious however, that any mechanism which will admit of the product being treated by the agent described can be used.

Dated this 25th day of January 1905.

5

For the Applicants:

WM. P. THOMPSON & Co.,
6 Lord Street, Liverpool.

COMPLETE SPECIFICATION.

"Improvements in or relating to the Treatment of Foodstuffs, more especially Cereals and their Products."

10

We, JOSEPH APPLEBY, of 35, Pembroke Road, Bootle, and ARTHUR JOHN BANKS, of 57, Lawton Road, Waterloo, near Liverpool, both in the County of Lancaster, Miller and Analytical Chemist respectively, do hereby declare the nature of this invention and in what manner the same is to be performed, to be particularly described and ascertained in and by the following statement:—

15

It has long been known that both living and dead organic matter, are more or less susceptible to the action of solar light as well as to varying portions of the visible and invisible rays of the solar spectrum. The influence of rays possessing great chemical activity in connection with the anabolic and metabolic changes of organised structure, has been rendered technically available by quite recent researches on the phenomena of radio-activity. Further, it has for some years been known that the Rontgen or "X" rays have a remarkable effect on flour and other materials, and they have been proposed for use in this connection but the danger of fire and the high charge for insurance entailed by the use of an electric current in milling operations has made the use of these rays prohibitory. Many varieties of food stuffs are capable of being improved in either their physical appearance or their physiological effect, by a modification of the molecular structure. Such alteration of chemical structure requires energy to be expended. Taking plant life as an instance the amount of energy available is really immense; but, unfortunately, the time required for the various steps in its transformation is also very considerable and from the manufacturers point of view altogether too excessive to admit of the natural time and order of the changes to be carried out. Hence, any means by which this period of time can be reduced, should be of commercial value.

20

25

30

35

Now our invention is designed to bring about an improvement in the condition of food stuffs, especially in respect to cereals and their products, such as flour, by inducing within the grain or the products therefrom, chemical changes similar to those which occur in nature, or in the case of flour and cereal products by storage for several months. The invention consists essentially in exposing the substance to be treated to the action of the emanation from radium or radio-active substances or to the action of the α (alpha) β (beta) or γ (gamma) rays derived from radium or other radio-active substances.

40

Treatment by exposure, under proper conditions, to such rays or emanations, very materially reduces the time required to mature cereals and their products and food stuffs amenable to such action.

45

In the case of flour, semolina, and the like, a very great improvement is effected in respect to the purity of colour, the property of "strength" and

Improvements in or relating to the Treatment of Foodstuffs.

their general keeping quality. Whilst in all cases of such treatment, there is the exceptionally marked advantage of an entire absence of the direct use or employment of chemical compounds in the ordinary sense of the term.

5 In our experiments we have brought the substance to be treated under the influence of a current of air aspirated from, or blown through a chamber, receptacle or vessel containing radium bromide. Other radio-active substances may be employed, but with not such a good result, as their ionising action is less energetic.

10 We have mentioned the current of air aspirated from or blown through a chamber merely to illustrate what we have found to be a convenient way of applying the emanations. It is obvious however, that any mechanism which will admit of the product being treated by the agent described can be used.

15 For the better understanding of the invention, we append the accompanying drawing of our experimental device which we have found very effective on various kinds of cereals, in which

Figure 1 is a sectional elevation;

Figure 2 a plan with the upper cover removed.

20 In these A is the spout varying in length according to the nature of material to be operated upon, and the quantity passing through. B is a glass or metal plate in this spout, and C a second glass or metal plate. These two plates are the entire width of the spout. E is a pipe coming from between the plates and delivering its air into the spout at or near the lower end. F is an entrance for air between plates B C at the other end.

25 The mode of action is as follows:—The glass plates B and C are painted over with radium bromide in any convenient solution, and the surface when dry protected by a coating of collodion or other suitable varnish. The spout is inclined at any angle suited to the nature of the material to be operated upon, and to the time of its exposure to the direct influence of the rays. The air enters at F, passes down between the radium bromide walls, and passes 30 through the pipe E to the spout A by which it rises to the top and there escapes into the air, or after the removal of any suspended matter, dust, *etcetera*, the air may be returned to the radium-chamber. Our experimental spout has a space about three-quarters of an inch wide between B and C, and is about 20 feet long. The material is fed down it with a steady feed. The device 35 illustrated is merely shown by way of example, and the invention is not in any way confined thereto.

Having now particularly described and ascertained the nature of our said invention, and in what manner the same is to be performed, we declare that what we claim is;—

40 1. The process of treating flour, middlings, grain or other cereals by exposing them to the emanation or rays from radio active substances, substantially as described.

45 2. The apparatus for treating cereals, flour, and other food stuffs in which the emanations or the actual alpha, beta, or gamma rays from radio active substances are caused to act upon the materials substantially as described.

Dated this 20th. day of July 1905.

For the Applicants:—

50 WM. P. THOMPSON & Co.,
6, Lord St., Liverpool & 322 High Holborn, London W.C.,
Chartered Patent Agents.

[This Drawing is a reproduction of the Original on a reduced scale.]

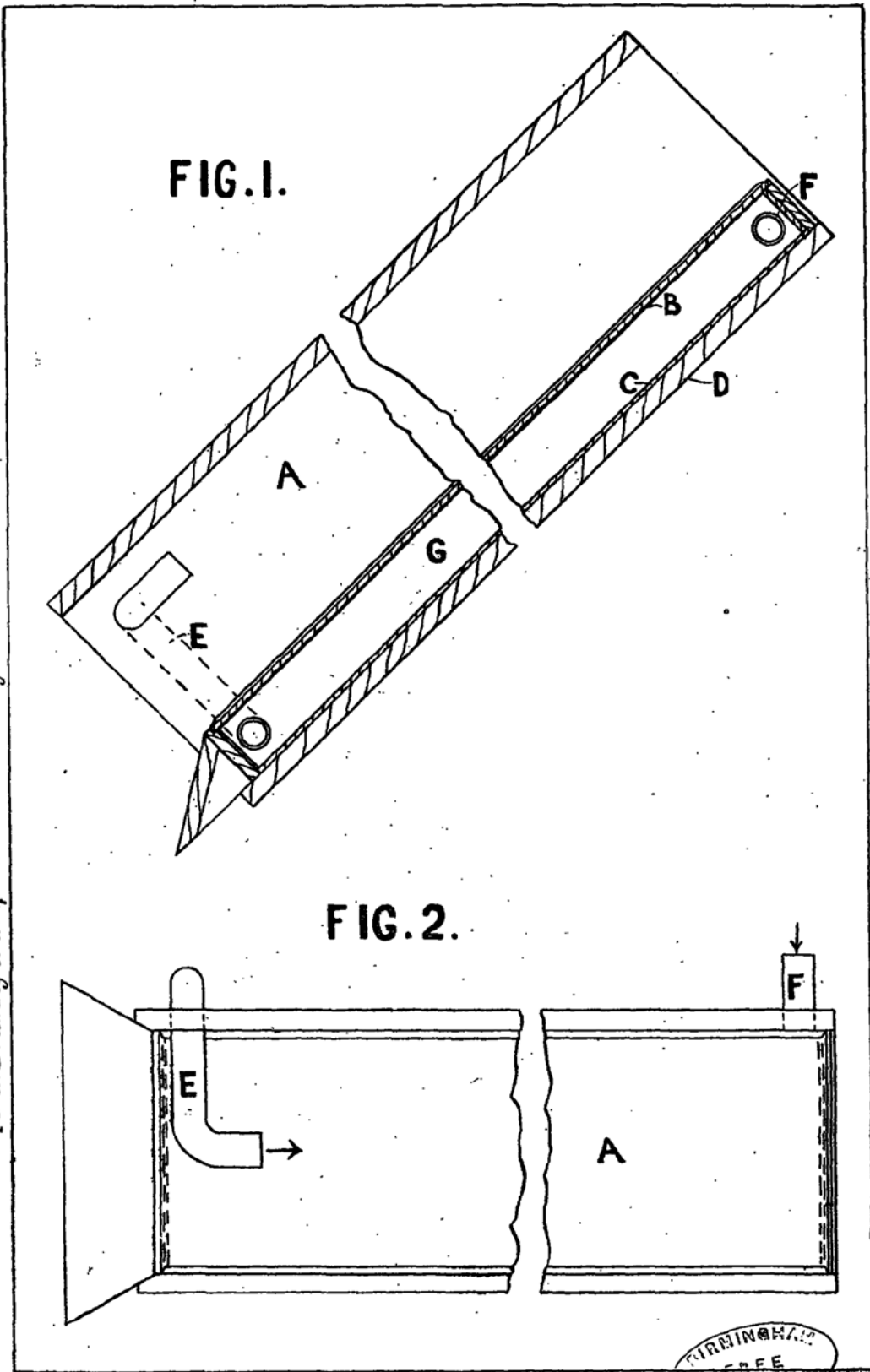

PRINTED BY
FREE
MAYHEW & CO. LITHO.